

8'0" WIDE MOBILE STORAGE OFFICES

GENERAL SPECIFICATIONS

- Pre-finished gypsum ceilings
- Aluminum exterior
- Fluorescent ceiling lights
- 120/240 Volt electrical panel – 60 amp main panel
- 3000 Watt wall heater
- 8000 BTU thru wall A/C

Office includes:

- Built in desk with file cabinet and plan table
- Panel walls
- (3) 46" x 27" Horizontal sliding windows
- 3680 Door with vision panel

Storage includes:

- Luan walls
- 3/4" Plywood decking floor
- (2) 30" x 14" Horizontal sliding windows
- 72" x 68" Steel roll up door

Mobile office specifications and interior designs may vary slightly from trailer to trailer.



RENT, LEASE OR PURCHASE

We have rental, lease and purchase options available to meet your needs.

SATELLITE SHELTERS

For over 35 years, Satellite Shelters has been a national provider of temporary and permanent space solutions including mobile offices, modular buildings, ground level offices, containers and blast resistant modules.

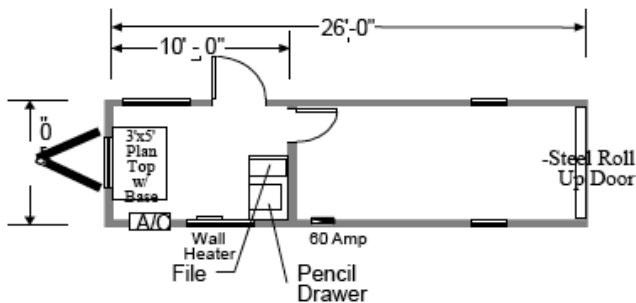

830MSO – 8' x 26' Box Size

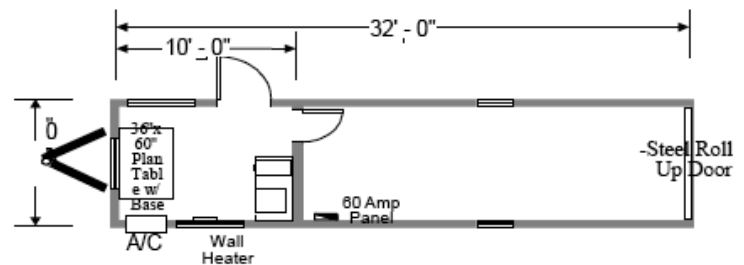

836MSO – 8' x 32' Box Size



Proud Member



Proud Member



Contract Holder
Veteran-Owned, Small Business
GS-07F-6100R

www.satelliteco.com
800-453-1299
inquiry@satelliteco.com